

REV.	ECN NO.	APPD	DATE
A0	RELEASE	Jeff Zhou	08/08'13

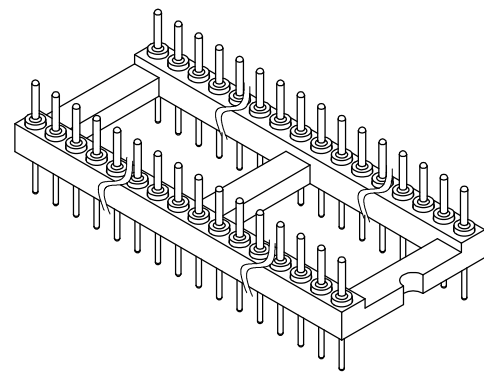
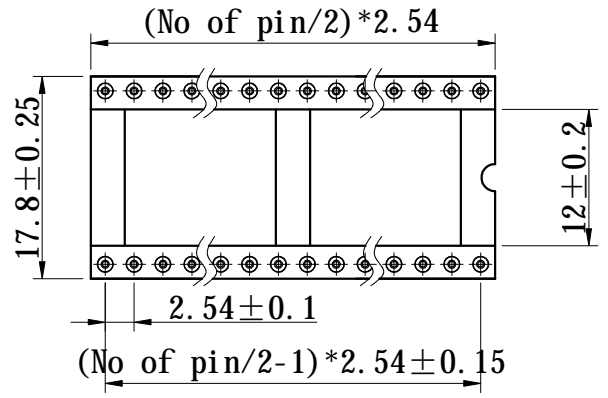

ELECTRICAL:

Current rating:
3.0Amps/Contact MAX
Contact resistance:
20mΩ / Contact MAX
Insulation resistance:
1000MΩ at V=100V MIN
Operating voltage:60V AC/DC

MECHANICAL

Operating temperatures:
-40°C ti +105°C
Soldering Temperature:
+240°C,10S MAX

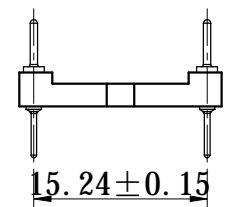
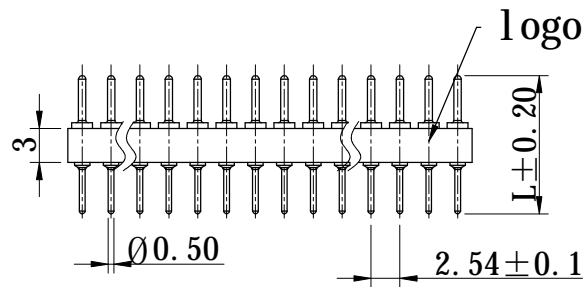

Material

PIN: Brass,machined
Plating(PIN):50u" NI,GOLD FLASH
Insulator body(Black):
PBT or other(UL94V-0)

Ordering Information

1 1 1 - X X X - X X Z - X X X X - X X

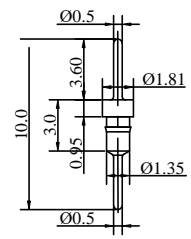

10.0mm PIN
P/N0: P-127-1000-000-001

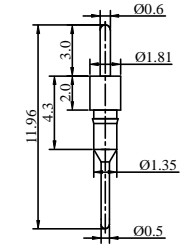

11.96mm PIN
P/N0: P-127-1196-200-001

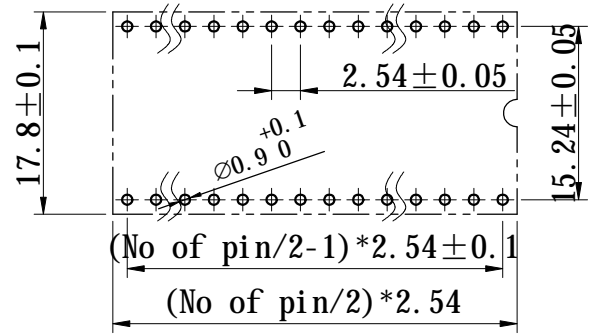

P. C. B LAYOUT

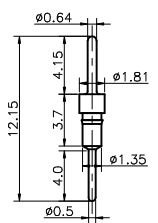

12.15mm PIN
P/N0: P-127-1215-000-001

Pin#	代码	说明	待间距 (型号)	代码	说明	间距 (PITCH)	代码	说明	Pin plated (L)	代码	说明	间距材料	代码	说明	间距	
10	10Pin	3	7.62	1	有孔	0	2.54	Tin 200u"	8001	8011	6001	8101	0	PBT	0	nextcon
64	64Pin	4	10.16	2	无孔	7	1.778	Gold flash	8002	8012	6003	8102	3	PA46	1	无
		6	15.24					Gold 15u"	8004	8014	6004	8104	6	PPS		
		7	19.06					Gold 30u"	8006	8016	6006	8106				

X±0.5	UNITS	mm	NAME:
.X±0.38			XX6圆针IC插座/XX.XXmm/XXPin
.XX±0.25	MAT'L	PART NO.:	111-XX6-10Z-XXXX-0X
.XXX±0.08			APPD:
X°±2°	FINISH	CHKD:	DR:
			Jeff Zhou

JUNHAD 深圳市君灏精密工业有限公司
SHENZHEN JUNHAD ENGINEERING CO.,LTD

TITLE:
XX芯2.54pitch圆针IC插座-XXmm圆针插座

DWG NO.:

EP-C-111-6003-301

SCALE	SHEET	REV.
1:1	1/1	A0

THESE DRAWINGS AND SPECIFICATIONS ARE THE PROPERTY OF JUNHAD ENGINEERING CO.,LTD. AND SHALL NOT BE REPRODUCED COPIED OR USED IN ANY MANNER WITHOUT THE PRIOR WRITTEN CONSENT OF JUN HAO ENGINEERING CO.,LTD

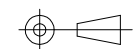

08/08'13